

#upgrade kit

UPG01VRN41090
SKU

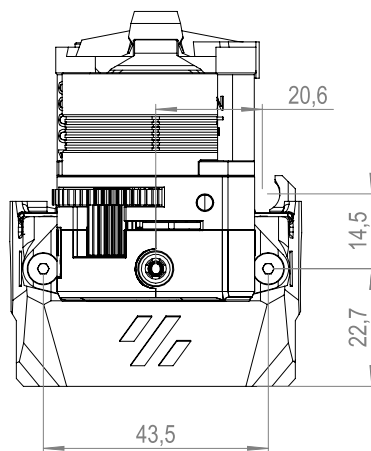
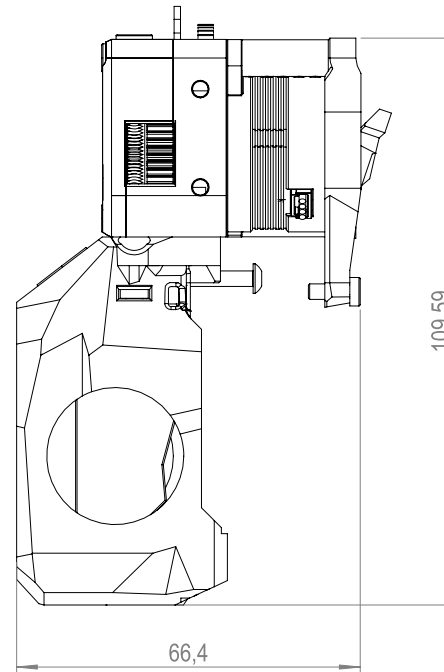
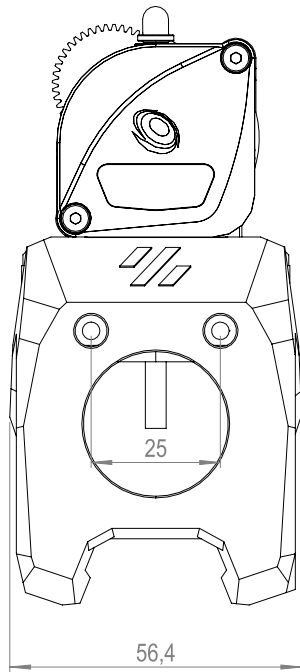

NAME LGX Lite V2 for Voron V0.2 Upgrade Kit

TYPE Upgrade Kit

SKU UPG01VRN41090

Specifications

Upgrade Type	Direct extruder
Filament Diameter	1.75 mm
E-Steps Change	Required to 562 @1/16 micro stepping
Extruder Current Change	Required to 450 - 700 mA (RMS)
Extruder (Included)	Bondtech LGX Lite V2 (TDS here)
Compatible Extruders (alternative)	LGX Lite, LGX Lite PRO
Compatible Printers	Voron 0.2
Compatible Hotends	Stock, Mosquito, Mosquito Magnum
Compatible Materials	Abrasive, rigid, semi-flexible, flexible
Compatible Bed Leveling Sensors	Pinda, Pinda 2, Minda, Superpinda

Required Tools	Stock Items Reused	3D Prints Required
2mm Hex Key	2 x M3x35	None
2.5mm Hex Key	Motor (optional)	
Side Cutters	Hotend (optional)	
Utility Knife		

#upgrade kit

UPG01VRN41090

SKU

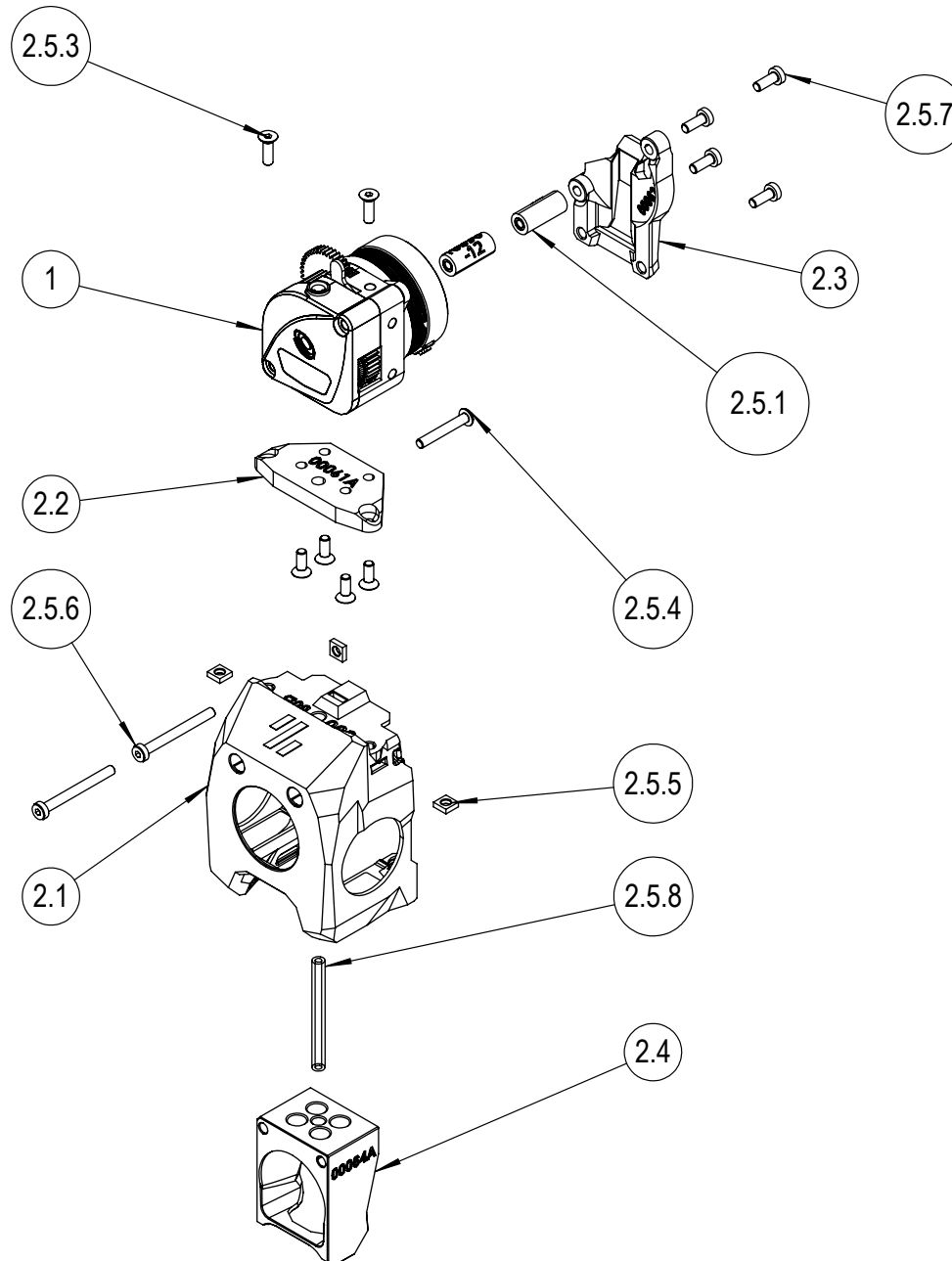

Item Ref.	Qty.	Description	Article Number
1	1	LGX Lite Large Gears eXtruder V2	EXT01LGX41003
2	1	LGX Lite for Voron V0.2 Accessory Set	ACC01VRN41091
2.1	1	LGX Lite for Voron V0.2 Cowling	02PRT61HSP00060
2.2	1	LGX Lite for Voron V0.2 eXtruder Plate	02PRT61HSP00061
2.3	1	LGX Lite for Voron V0.2 Back Stabilizer	02PRT61HSP00062
2.4	1	LGX Lite for Voron V0.2 Stock Hotend Adapter	02PRT61ADP00064
2.5	1	LGX Lite for Voron V0.2 Hardware Accessories	02FST00STS00075
2.5.1	2	Voron V0 Strain Relief Spacer	10090-12
2.5.2	4	M3x8 Untreated Allen screw Countersunk	M3X8FSOBEH
2.5.3	2	M3x10 Untreated Allen screw Countersunk	M3X10FSOBEH
2.5.4	1	M3x20 Button Head Hex Stainless Steel	MK6SM3X20
2.5.5	3	Square nut M3	FKM3
2.5.6	2	Low Head Cap Screw Black Oxide M3x30	M3X30L
2.5.7	4	Low Head Cap Screw Black Oxide M3x8	M3X8L
2.5.8	1	Mosquito 40mm PTFE Tube 4.0/2.0 mm	12003