

# #upgrade kit

UPG01NYC41021  
SKU

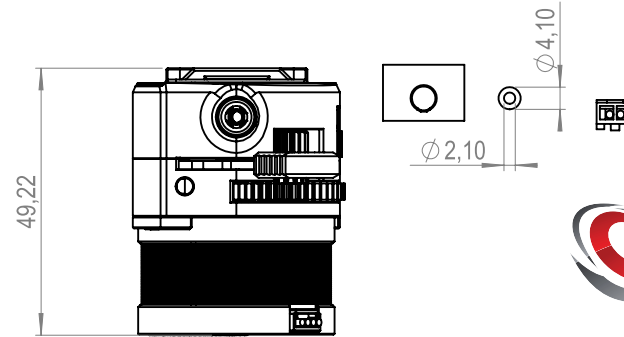
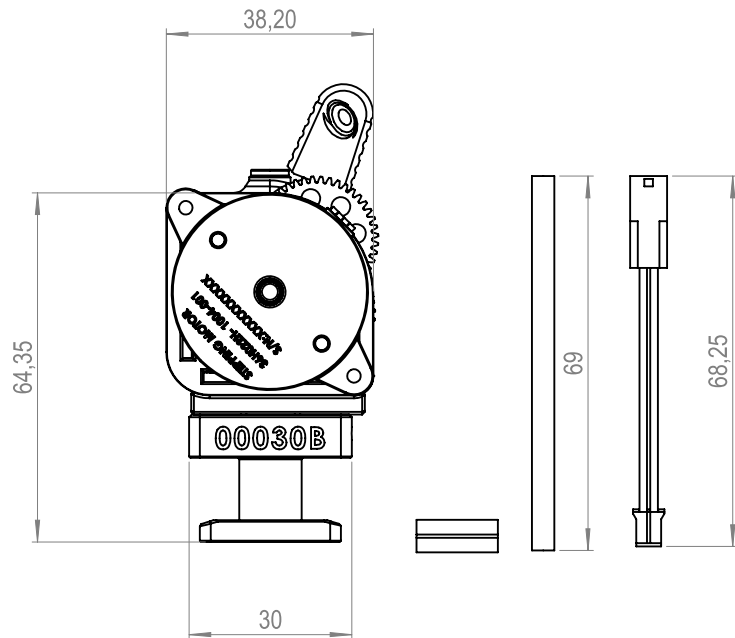

NAME LGX Lite PRO V2 for Vyper & Mosquito  
Magnum+

TYPE Upgrade Kit Direct Drive

SKU UPG01NYC41021

Specifications	
Filament Diameter	1.75mm
Compatible Printer	Anycubic Vyper, Anycubic Kobra Plus, Kobra Max
Includes	LGX Lite PRO V2, LGX Lite Extruder Mount, Slice Engineering Mount for LGX Lite
Estep	800 @ 1/16 microstepping 1600 @ 1/32 microstepping
Drive Wheels	All Metal Hardened Steel
Top Fitting Tube Od	4.10 mm
Materials Compatibility	Abrasive, rigid, semi- flexible, flexible and soft
Mounting	bottom (4 points); right (2 points), left (1 point), front to motor (2 points), top (1 point)
Max Tightening Torque	0.3Nm
Housing	PA 12 GF
Working Temperature	Up to 100°C
Weight	150 g

Comments	
	Nitrocarburized SS1914, Surface coating
	See drawing above for more details about mounting points location and thread dept
	SLS printed housings with glass filled Nylon (PA12 GF) Motor selfheating ~80°C @ 1000mA + Chamber temp must not exceed 180°C Net weight

Specifications		Comments
Motor Insulation Class	Class-H	Up to 180°C
Push Force		
Tension	Adjustable with 5 fixed positions	Abrasive, 1 Rigid Materials. 2-3 Semi- flexible. 4-5 Flexible/Soft
Max Peak Current 1.0A	Recommended current 500-700mA	for extended life, 600mA is recommended
Stepper Motor	Nema14 Round Stepper 22mm Ø36mm	
Motor Connector	JST-XH 4-pin connector	
Filament Diameter	1.75 mm	
Lubrications	Berutox FB22	Visual inspection every 100 print hours. Clean and apply new lubrication on the gears if they are dry
Ce Certified	Yes	
RoHS	Yes	
REACH	Yes	

# #upgrade kit

UPG01NYC41021  
SKU

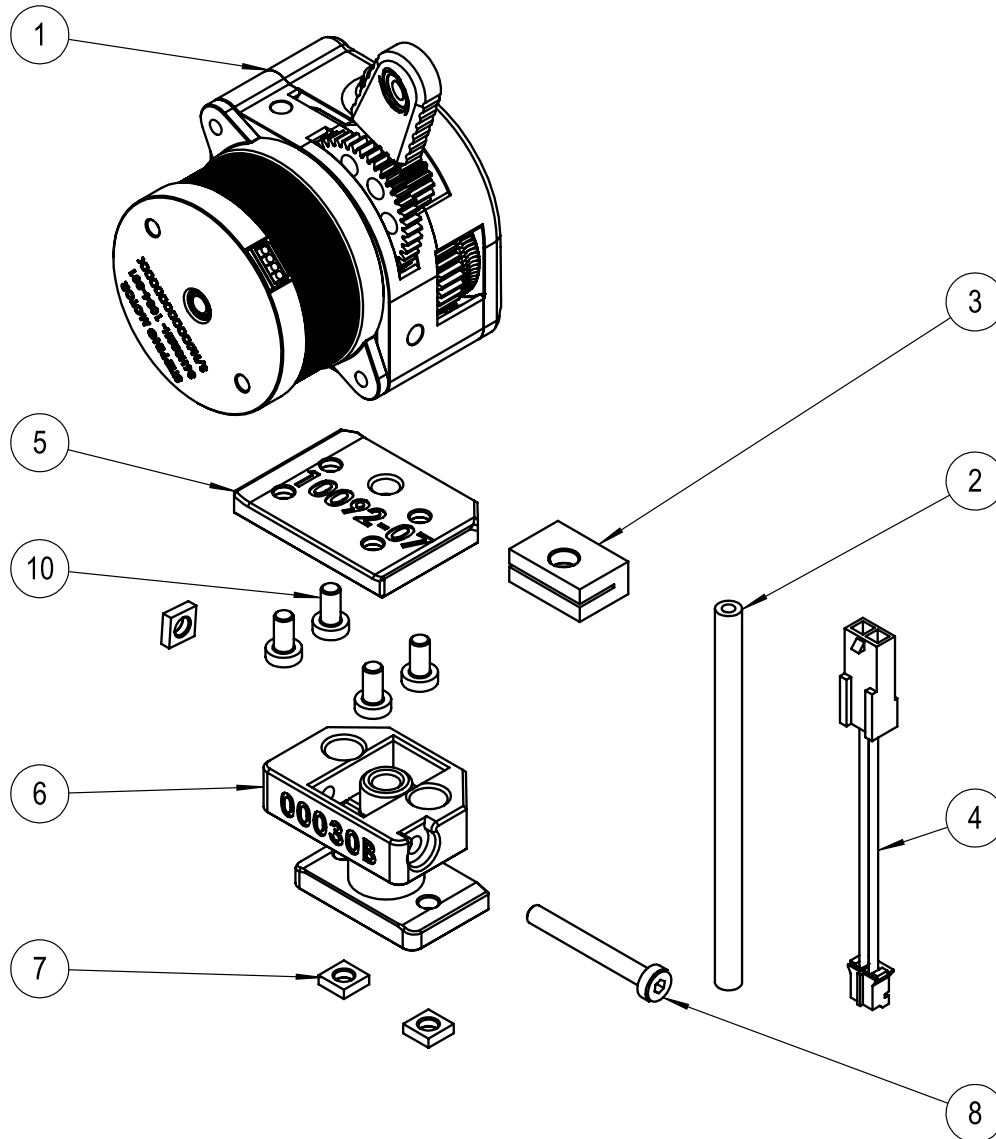

Item Ref.	Qty.	Description	Article Number
1	1	LGX Lite Large Gears eXtruder PRO	EXT01LGX41014
2	1	PTFE Tube	
3	1	Bondtech Capricorn Cutting Fixture for DDX and LGX Lite	
4	1	LGX Lite AnyCubic Vyper Fan Cable	02LCT00CBL00037
5	1	LGX Lite Arrow Extruder mount	10092-07
6	1	Anycubic Vyper SE mount for LGX Lite	02PRT61ADP00030
7	3	Fyrkantsmutter M3	FKM3
8	1	Low Head Cap Screw Black Oxide M3x25	M3X25L
9	2	Socket Head Screw M3x35	M3X35OBEH
10	4	Low Head Cap Screw Black Oxide M3x6	MX3X6L