

Felfil -spooler-

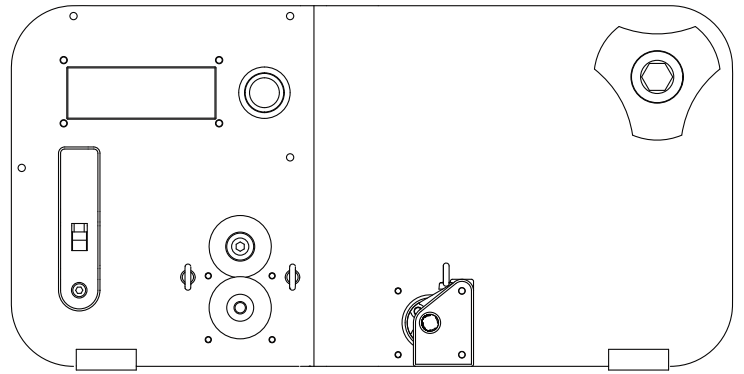
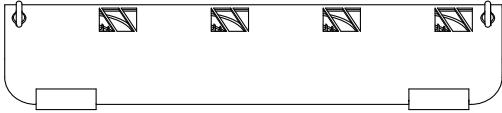

Technical Data

Overview

Diameter Range

0,5 mm to 3 mm

Accuracy

10 micron

Compatible materials

PLA, ABS, HIPS, PETG, PA(6,12), PMMA,
HDPE, LDPE, TPU, TPE, PVA

Spool

Max Spool Load

1 kg

Spool Size

100mm Width
220 mm Diameter

Energy

Consumption average

50 W

Consumption max.

60 W

Voltage

110 - 230 V

Fan

RPM Range

0 - 250

Size & Weight

Dimensions

350 x 180 x 108 mm

Weight

4 kg