

Felfil

filament extruders

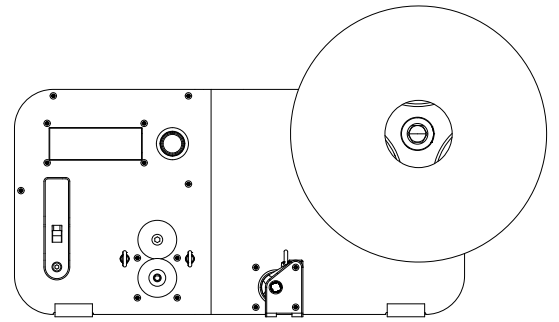
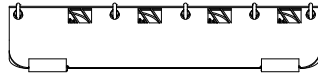
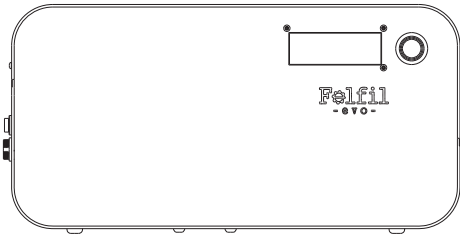

Technical Data

Overview

Temperature max.

250°C (300°C on requests)

Heaters

3x40W cartridges

Compatible materials

PLA, ABS, HIPS, PETG, PA(6,12), PMMA, HDPE, LDPE, TPU, TPE, PVA

Output

RPM Range

0-9

Filament diameter range

0,5 - 3mm

Diameter sensor accuracy

10 microns

Nozzle extruder

1,75mm- 2,85 interchangeable

Energy

Consumption average

110 W

Consumption max.

240 W

Voltage

110 - 230 V

Capacity

Hopper volume

1 liter

Spool size

Diameter 220 mm (8.6 inches)

Width 100 mm (3.9 inches)

Size & Weight

Space needed

100 x 18 x 10 cm

Weight

9 kg