

#extruder

EXT01DDG41016

SKU

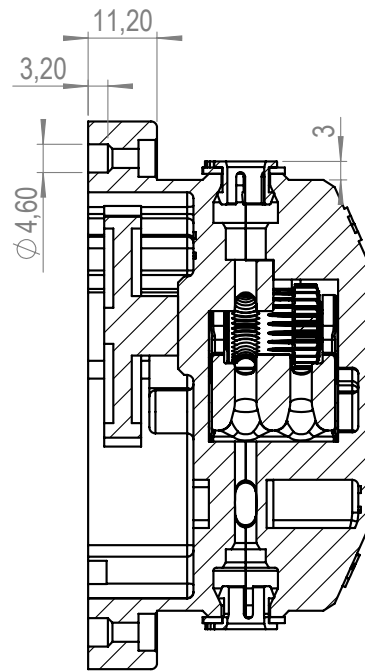
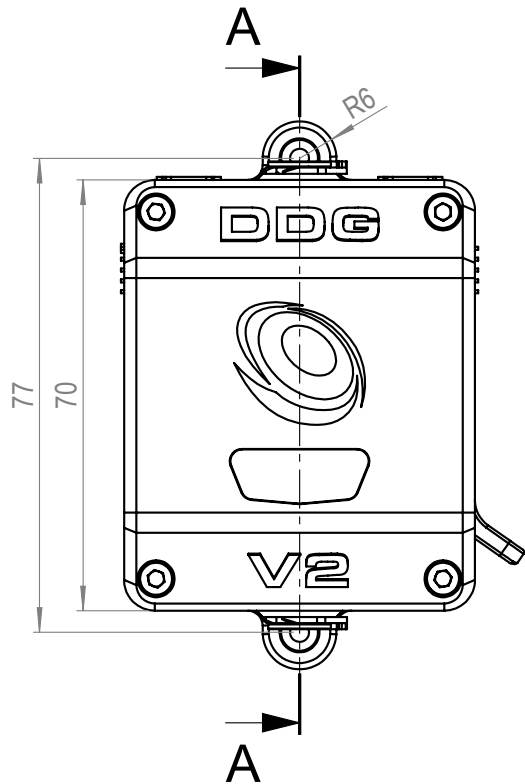

SECTION A-A

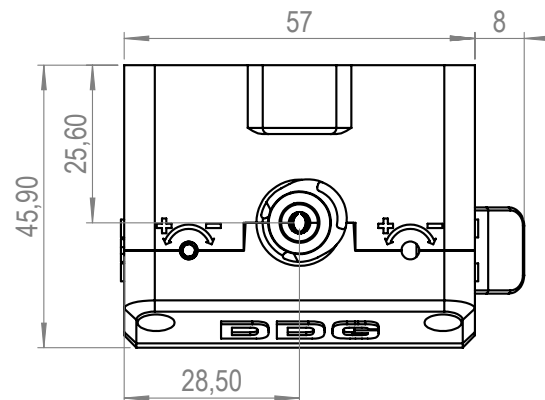

NAME DDG V2 Extruder Standard

TYPE Extruder

SKU EXT01DDG41016

Specifications

Printer Compatibility UltiMaker 2, 2-Extended 3, 3s, 5s, 7s.

Compatible With Material Station Yes

Filament Tension Spring Loaded with Quick Release

Weight 159g

Comments

UltiMaker 2, 2 Extended and 3 need cable converter to change feeding direction

#extruder

EXT01DDG41016
SKU

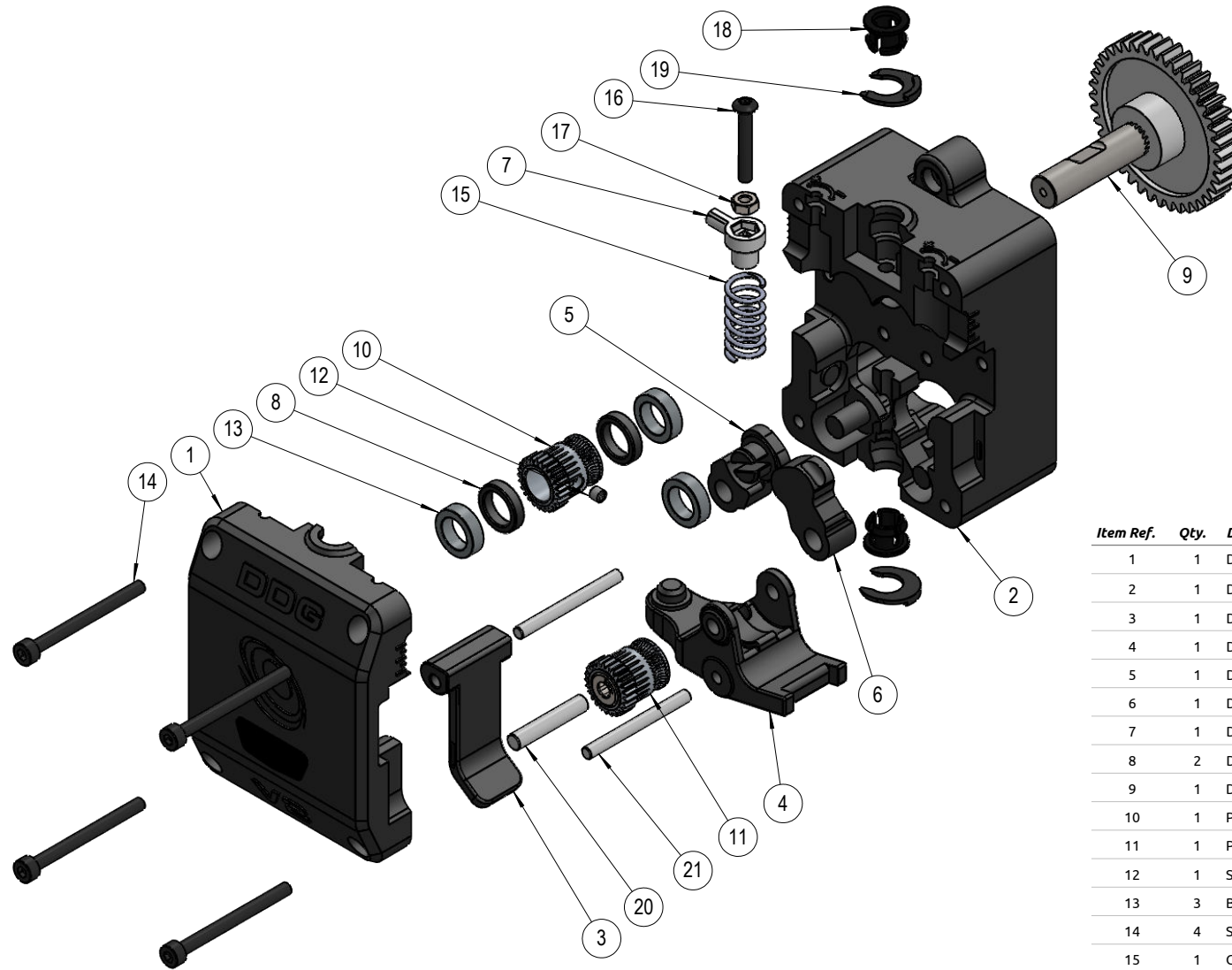

Item Ref.	Qty.	Description	Article Number
1	1	DDG V2 Housing Front	02PRT61HSP00020
2	1	DDG V2 Housing Rear	02PRT61HSP00021
3	1	DDG V2 Lever	02PRT61HSP00022
4	1	DDG V2 Idler	02PRT61HSP00023
5	1	DDG V2 Bearing Idler	02PRT61HSP00024
6	1	DDG V2 Plug	02PRT64HSP00026
7	1	DDG V2 Indicator	02PRT64GDE00041
8	2	DDG V2 Spacer	02PRT64SPR00042
9	1	DDG V2 Assembled Shaft	02PRT00SFT00043
10	1	Primary drivegear 3.0 Ø8	11004
11	1	Pressed Secondary Drivegear 3.0 Ø8.0	11006-T
12	1	Setscrew M3x3.0	P6SSM3X3
13	3	Ball Bearing 8x12x3.5	MR128ZZ
14	4	Socket Head Screw M3x35	M3X35OBEH
15	1	Compression spring SS2331 1.25X8X22	6037
16	1	Button Head Hex Stainless Steel M3x20	MK6SM3X20
17	1	M3-Nut	93400301
18	2	Push-fit Collar 6mm	12017
19	2	Bowden Clip 2.85, 1mmt	02PRT64CLP00044
20	1	Hardened Cylindrical Shaft 4x22	STIFT4X22M6
21	2	Hardened Cylindrical Shaft 3x32	STIFT3X32M6