

#extruder kit

EXT-KIT-98-01
SKU

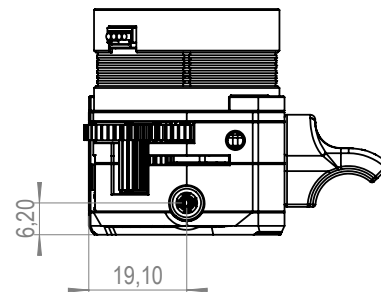
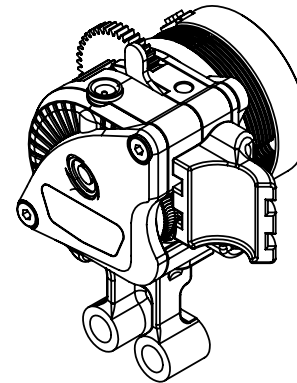
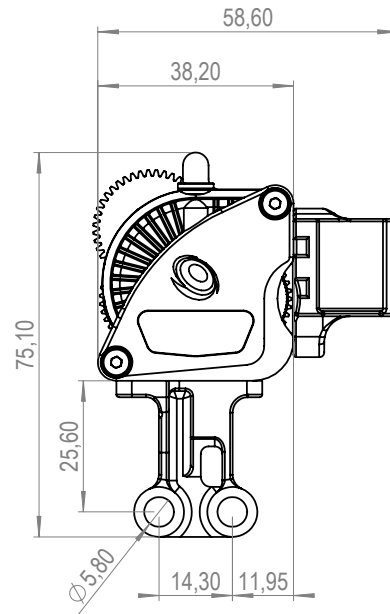
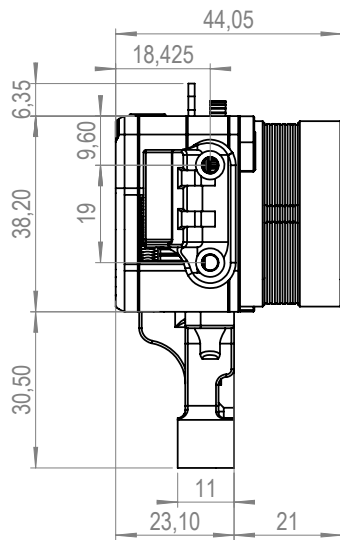

NAME Creality Ender 7 LGX Lite
TYPE Upgrade kit, Direct Drive
SKU EXT-KIT-98-01

Specifications

Extruder	LGX Lite
Filament Diameter	1.75mm
ESTEP	562
Filament Tensions	3 Fixed Lever Position Position 0 - Open • Position 1 - Rigid Materials • Position 2 - Flexible Material
Stepper Motor	Nema 14 Round stepper 1.8°, 20mm, $\varnothing 36$ mm
Recommended Current	0.45 to 0.60A
Printable Materials	Rigid, Abrasive, Semi-Flex, Flexible
Recommended Retraction Speed	35mm/s
Recommended Retraction Length	Rigid: 0.4-1.0mm Flexible: 1.5-4mm <small>Retraction distance will vary depending on nozzles size, filament type etc.</small>
Weight: Extruder	48g
Weight: Stepper Motor	93g
Weight: Accessories	17g

#extruder kit

EXT-KIT-98-01

SKU

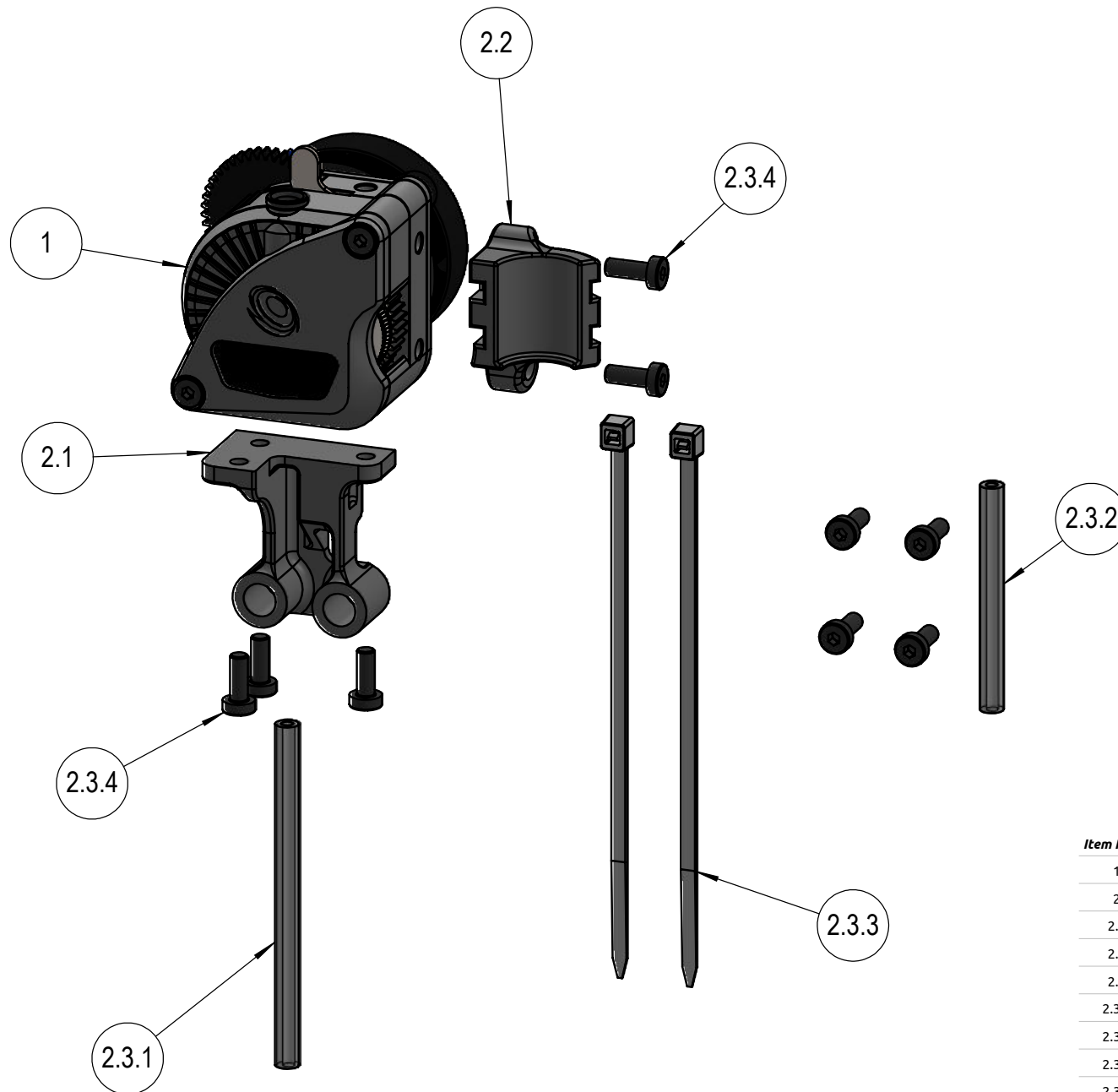

Item Ref.	Qty.	Description	Article Number
1	1	LGX Lite Large Gears eXtruder	EXT-LGX-LITE
2	1	Mounting Set for LGX Lite on Ender 7	15181
2.1	1	LGX Lite Ender 7 Mount	10101-01
2.2	1	LGX Lite Ender 7 Cable holder	10101-03
2.3	1	Creality Ender 7 Accessories Bag	15184
2.3.1	1	Ender 7 60.8mm PTFE Tube 4.0/2.0 mm	12003
2.3.2	1	Mosquito 40mm PTFE Tube 4.0/2.0 mm	12003
2.3.3	2	Zip-tie 2.5x100	15048
2.3.4	9	Low Head Socket Cap Screw M3x8	M3X8L